

1

2

3

4

Rev.A

date

Description revision

A

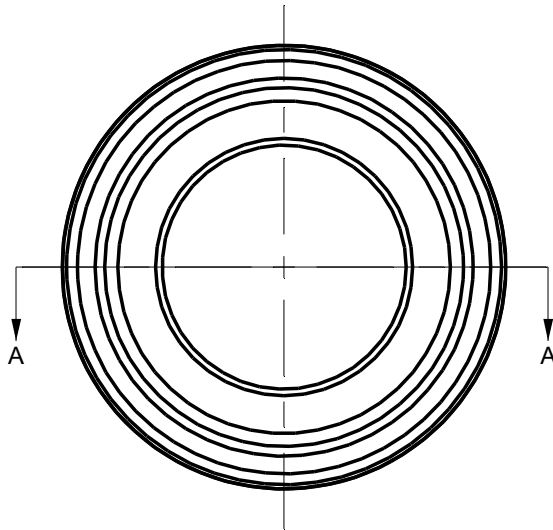

B

Ø20

Ø11

C

23

D

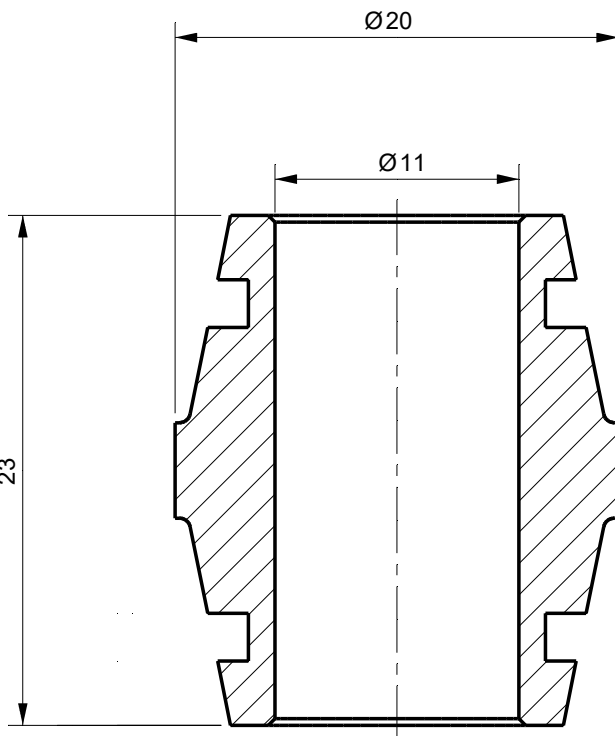

E

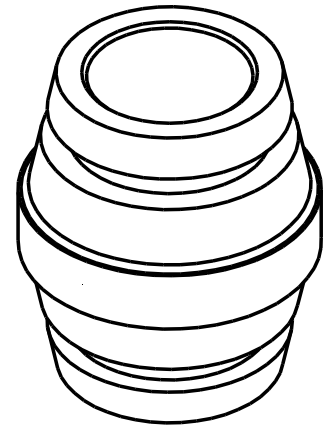

Section A-A

Tolerances

Unless Otherwise Specified
ACC. DIN-ISO 2768 -1and 2
Angular +/- 0,3°
Corners <0,2x45° / R<0,2

Finish

-

Material

St.St. 1.4122

Dimension (No Decimals)

0 t/m 6 6 t/m 30 30 t/m 120 120 t/m 400 400 t/m 1000

Tolerance

0,1 0,2 0,3 0,5 0,8

Name**Date****Remarks****Drawn**

28-9-2023

Checked**Description**

Double Cone
M24X1.5 Sealing

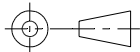
Projection

Drawing remains the property of
Salomon Jetting Parts B.V.

Unit

mm

Number**Project**

F



Salomon Jetting Parts B.V.
Reedijk 8-1
3274 KE Heinenoord
www.sjpbv.com
info@sjpbv.com
+31 (0) 88 126 1900

Size
A4

Drawing nr.**01.01946-S****Rev****A**

Scale
3:1

CAD File**Sheet****1 of 1**