

1

2

3

4

Rev.A

date

Description revision

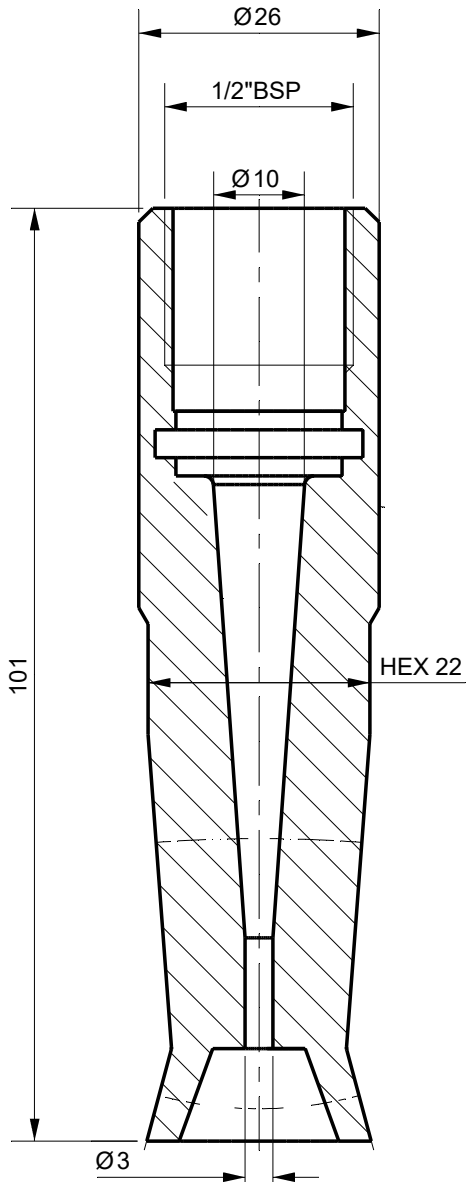
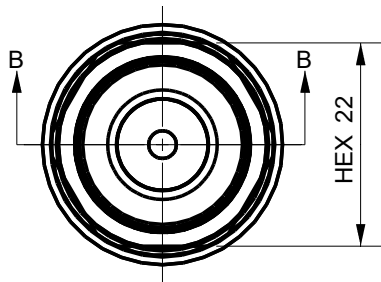

Section B-B

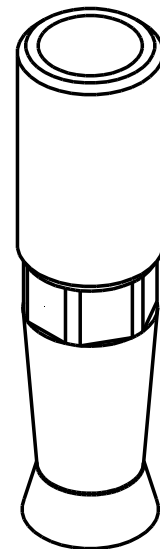
**Tolerances**

Unless Otherwise Specified  
ACC. DIN-ISO 2768 -1 and 2  
Angular +/- 0,3°  
Corners <math><0,2 \times 45^\circ / R < 0,2</math>

**Finish**

Vacuum Hardening HRC 55

**Material****Dimension (No Decimals)**

0 t/m 6	6 t/m 30	30 t/m 120	120 t/m 400	400 t/m 1000
0,1	0,2	0,3	0,5	0,8

**Tolerance**

0,1

0,2

0,3

0,5

0,8

Name

Date

Remarks

Drawn

1-3-2024

Checked

Projection

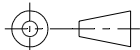

Drawing remains the property of Salomon Jetting Parts B.V.

Unit mm

Number

**Description**

HP Longcast Nozzle  
1/2" BSPF - Ø3

**Project**

Salomon Jetting Parts B.V.  
Reedijk 8-1  
3274 KE Heinenoord  
www.sjpbv.com  
info@sjpbv.com  
+31 (0) 88 126 1900

Size  
**A4**

Drawing nr.

**1963.12.3**

Rev

**A**

Scale  
**1.25:1**

CAD File

Sheet

**1 of 1**