

1

2

3

4

Rev.A	date	Description revision

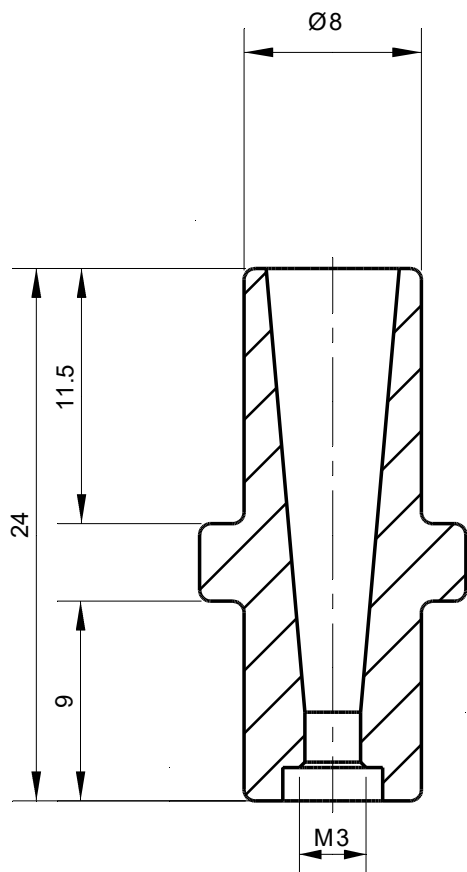
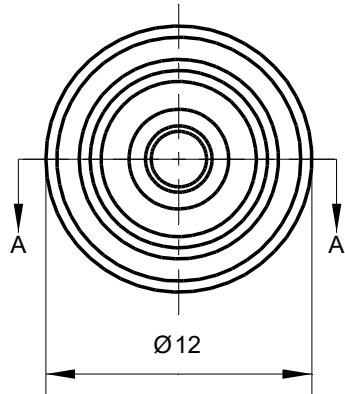

Section A-A

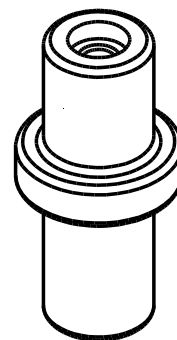
**Tolerances**

Unless Otherwise Specified
ACC. DIN-ISO 2768 -1and 2
Angular +/- 0,3°
Corners <0,2x45° / R<0,2

Finish

Vacuum Hardening max RC 49

Material

Dimension	0 t/m 6	6 t/m 30	30 t/m 120	120 t/m 400	400 t/m 1000
Tolerance	0,1	0,2	0,3	0,5	0,8

Name

Date

Remarks

Description

Round Jet Nozzle type A M3

Drawn

15-4-2021

Checked

Projection

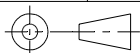

Drawing remains the property of
Salomon Jetting Parts B.V.

Unit
mm

Number

Project



Salomon Jetting Parts B.V.
Industriestraat 17
3291 CC Strijen
www.sjpbv.com
info@sjpbv.com
+31 (0) 88 126 1900

Size
A4

Drawing nr.

SJP04.M3

Rev

Scale
CAD File

Sheet

1 of 1