



P.A. - S.r.l. - EQUIPAGGIAMENTI TECNICI DEL LAVAGGIO

VIA MILANO, 13 - 42048 RUBIERA (REGGIO EMILIA) - ITALY - Tel. +39 0522 623611 (10 linee)
 Fax +39 0522 629600 - R.E.A. RE 156319 - Registro Imprese RE 11535 - Mecc. RE 013446
 C.F. e P. IVA 01035950359 - Cap. Soc. i.v. € 1.560.000,00 - Codice Identificativo C.E.E. IT 01035950359
 ART. 2497 - BIS C.C. DIREZIONE E COORDINAMENTO BENETTI srl R.I. TRIB. DI RE 01480690351
<http://www.pa-etl.it> - E-mail: info@pa-etl.it

GRUPPO BANCO POPOLARE DI VERONA E NOVARA SWIFT VRBPIT2V492



VB 350 S– Unloader valve (discharging) with max. and min. pressure adjustment

Technical manual: **E 232**

Pressure regulating unloader valve.

At gun shut off, the water flow is bypassed at reduced pressure.

DN 10



- **60.1750.00** VB 350 S G 3/8 M F
- **60.1800.00** VB 350 SMM G 3/8 M F

- Assembly equipped with a high pressure proof compensation.
- Compact dimensions.
- Sturdy steel and brass construction.
- Fixing system for the max. and min. pressure
- **Sst seat for check valve, replaceable.**
- Nylon knob
- By-pass G1/2 F.
- Easy maintenance

Technical specifications

Part Number	Rated pressure bar - MPa	Permissible pressure bar - MPa	Minimum adjustable pressure bar - MPa	Max. flow rate: 40 l/min. Max temperature: 90°C (1)		Inlet Outlet bypass	Weight g
				(2)Trapped pressure at circuit closure %	(3)Pressure drop to reset bypass %		
60.1750.00	350 - 35	390 - 39	35 – 3.5	8	43	G3/8 MF	850
60.1800.00	350 - 35	390 - 39	35 – 3.5	8	43	G3/8 MF	920

(1) The valve has been designed for a continuous use at a water temperature of 60°C. It can resist for short periods at a maximum temperature of 90°C.

(2) This is the maximum pressure increase implemented in the circuit for the intervention of the valve and to bring all the fluid in bypass (percentage figures of the pressure set up)

(3) This is the pressure reduction necessary in comparison to the set up, in order that the valve brings back pressure in the circuit. (percentage figures of the pressure set up)

Instruction manual, maintenance, installation, spare parts. For a correct utilization, follow the directions of this manual Re-print them on the Use and Maintenance booklet of the machine.	n. 12.9232.00

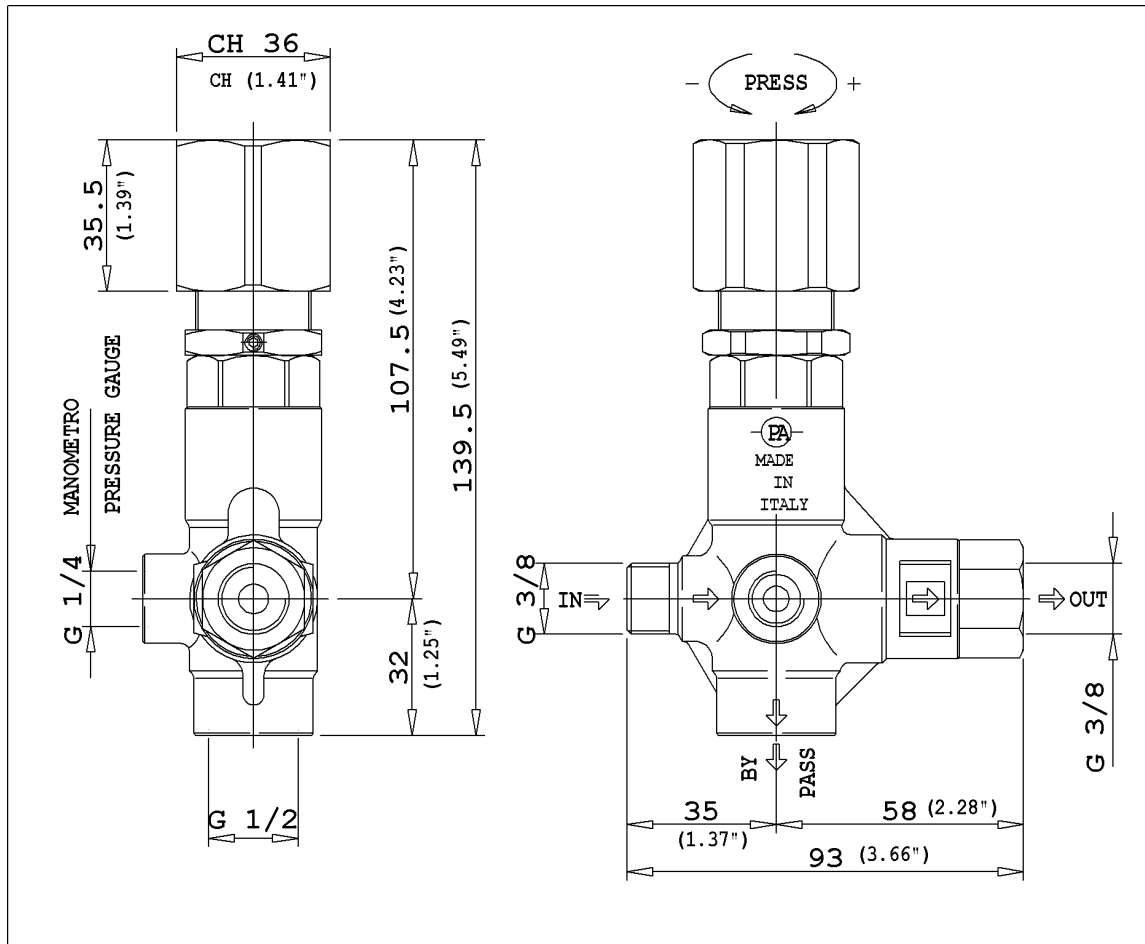
DIMENSIONAL DRAWING**INSTRUCTIONS****SELECTION**

This product is to be utilized with clean fresh water, even slightly additivated with normal detergents. For use involving different or corrosive liquids, contact the PA Technical department. Appropriate filtration should be installed when using unclean liquids. Choose the valve in line with the data of nominal running (system rated pressure, max flow and max temperature). **In any case, the pressure of the machine should not exceed the permissible pressure rate imprinted on the valve.**

INSTALLATION

This accessory, on a system that produces hot water, must be fitted **upstream the heat generator**. This product is bound to be incorporated on a finished machine. On a system that generates hot water, anticipate the fitting of accessories that limit the accidental increase of fluid temperature.

Always install a safety valve that protects the pressurized inlet channel.

Choose a correct nozzle size, which allows a regular discharge on bypass, at least 5% of the total flow of the system in order to achieve a constant pressure value and avoid troublesome pressure spikes at closure. If the nozzle wears out, the pressure drops. On installation of a new nozzle, re-adjust the system to the original pressure setting

OPERATIONS

The valve regulates the the max pressure of the system through a piston, which acts on a cone that, normally positioned, closes the bypass opening. A check valve cuts out the delivery section, the pressure of which controls the drive of the piston. Each regulation should be made when the system is in operation and the nozzle is opened.

ATTENTION: The nuts (pos.17-28) must never be removed mainly because, it is a mechanical safety feature that limits the max pressure and avoids serious damage to persons and machine.

DISCHARGE SYSTEM AND WATER ADDUCTION

The bypass line should be returned into a tank with deflectors. By using a direct pump recycle, with elevated pressure intake, it is necessary to install a pressure reducer in order to have an even flow supply and to protect the circuit intake.

When the system is opened and closed frequently, it is recommended to install a thermal protector valve (VT3 or VT6) in order to eliminate excessive temperature build.

PROBLEMS AND SOLUTIONS

PROBLEMS	PROBABLE CAUSES	SOLUTIONS
Valve vibration at lance opening	- Too much flow discharge, probably over 30% of pump flow	- Incorrect nozzle size. Replace with larger size nozzle
Frequent unloader recycles	Damaged check valve O ring Leaking connections Restricted bypass	Replace Check and renew Clean or adapt
Unloader does not reach pressure	Unloader not properly sized Piston O rings worn out Material matter between seat and shutter Worn out nozzle	Change spring or type of valve Replace Clean the seat Replace
Pressure peaks	There is not a min of 5% of total flow in bypass Excessive flow in bypass Spring totally compressed	Reset Change type of valve or adjust passages Loosen knob and change nozzle
Unloader does not bypass at low pressure	Jammed check valve Check valve O ring worn out Material matter on check valve	Clean or replace Replace Clean

REGULATIONS : *see norm manual*

The accessory hereby described bears the CE marking in accordance with the Norms and Directives applied on the Declaration of conformity.

For a correct utilization, follow the directions described in this manual and re-print them on the Use and maintenance manual of the machine.

Make sure that you are given the **Original Conformity Declaration** for the accessory chosen. The present manual is valid for all unloader valves named **VB 350 S**.

MAINTENANCE

Maintenance has to be carried out by **Specialized Technicians**.

STANDARD: every 400 working hours (circa 10,000 cycles), control and lubricate the seals with water resistant grease.

SPECIAL: every 800 working hours (circa 20,000 cycles), control the wear of the seals and internal parts and if necessary, replace with original PA parts taking care during installation and to lubricate with water resistant grease.

ATTENTION: reassemble the valve in the correct manner paying special attention to the Nuts (pos 17-28) which must always be in place.

The manufacturer is not to be considered responsible for damage as a result from incorrect fitting and maintenance-

Technical data, descriptions and illustrations are indicative and liable to modification without notice

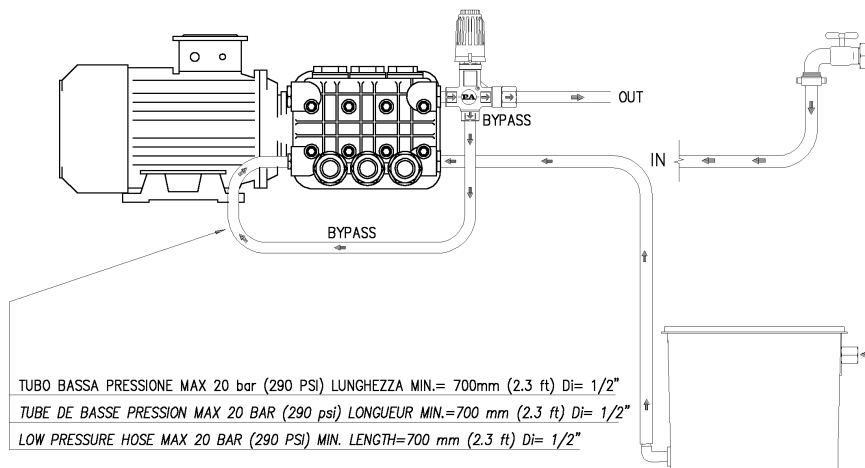
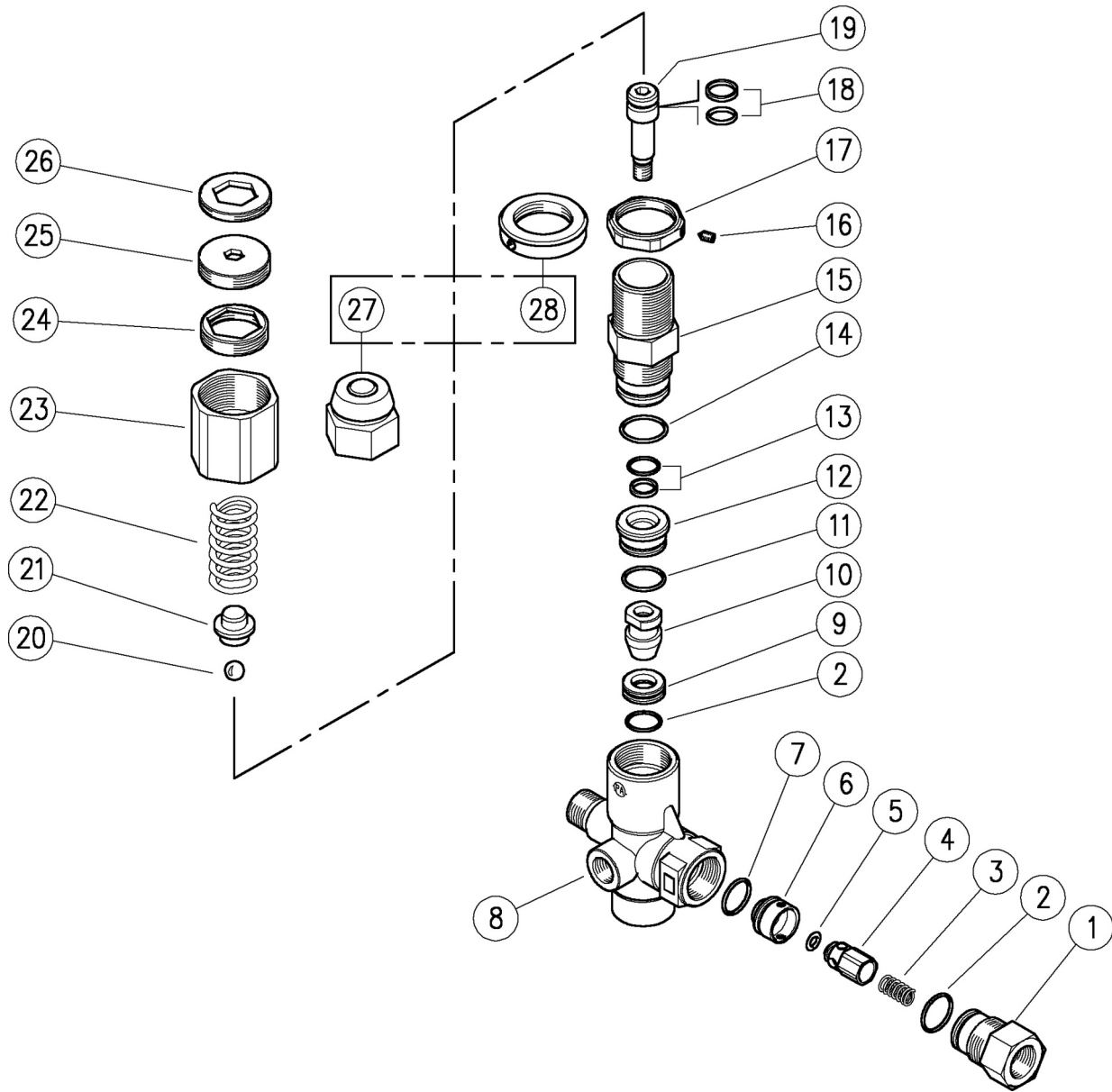

Fig.1

60.1750.00 VB350 S unload. 3/8MF Bsp byp:1/2F

60.1800.00 VB350 S unld.3/8MF Bsp byp:1/2F max/min



Pos.	P/N	Description	Q.ty	K1	K2	K3	K4	
1	60.1811.31	Shutter coupl., 3/8F Bsp brass	1					3
2	10.3066.01	O-ring, 1,78x15,6 mm Ni 85	2	•				10
3	60.0053.51	Spring, 0,7x9x20 mm Sst.	1					10
4	60.0052.51	Shutter pin, Sst.	1					3
5	10.3213.08	O-ring, 3x6 mm Ni 90	1	•				10
6	60.1807.51	Shutter seat, Sst.	1					3
7	10.3064.01	O-ring, 1,78x14 mm Ni 85	1	•				10
8	60.1801.35	Hous. -VB350, 3/8M c/sunk+1/4F Bsp brs.	1					3
9	60.1809.51	Seat, 11,6x19x6 mm Sst.	1	•				5
10	60.1808.51	Shutter pin, M8 Sst.	1	•				3
11	10.3068.01	O-ring, 1,78x17,17 mm Ni 85	1	•				10
12	60.1810.31	Spacer ring, 10,3x23,4x12,5 mm brass	1					5
13	60.0979.24	Stem seal, 10x14,9x2,2 mm+O-ring	1	•				5
14	10.3072.01	O-ring, 1,78x20,35 mm Ni 85	1	•				10

Pos.	P/N	Description	Q.ty	K1	K2	K3	K4	
15	60.1805.31	Piston holder, brass	1					3
16	16.2100.00	Set screw, DIN914 M4x4 mm	1					10
17	60.1814.31	Ring nut, M27x1 brass	1					5
18	60.0978.24	Piston seal, 9x14x2,2 mm+O-ring	1	•				5
19	60.1806.51	Piston, M8 Sst.	1					3
20	14.7443.10	Ball, 11/32" Sst.	1	•				10
21	60.1813.31	Spring rest pin, brass	1					5
22	60.1812.61	Spring, 4,5x15,8x47mm	1					3
23	60.1804.31	Valve regulating ring nut, brass	1					5
24	60.1803.31	Ring nut, M27x1 brass	1					3
25	60.1815.31	Lower adjustment ring nut, M32x1 brass	1					5
26	60.1816.31	Upper adjustment ring nut, M32x1 brass	1					5
27	60.1727.31	Valve regulating insert, brass (1)	1					5
28	60.1728.31	Ring nut, M27x1 brass (1)	1					3

Kit	P/N	Description	
K1	60.1818.24	Spares kit -VB350 12x1pcs.	1

(1) 60.1750.00